



DESCRIPTION

LMX's HY-LITE is perfect for food processing plants and is engineered to address the requirements of the food processing industry and to comply with NSF guidelines. With corrosion resistant and non-toxic aluminium, its IP69 ingress protection rating allows for usage in areas with high humidity and makes LMX's HY-LITE food safety high bay an excellent choice for food preparation areas. The perfect choice to illuminate food preparation areas where colour correlation and the ability to see clearly is of paramount importance. With optimal lighting distribution the HY-LITE helps in minimising dust particles, grease build up and hazardous fragments entering the food production area.

KEY FEATURES

- High luminous flux – up to 33600 lm.
- Designed to operate 24 hours per day
- Unique internal thermal management structure.
- Suitable for high humidity, easy to clean.
- High quality polycarbonate optics.
- -30° – +50°
- Advice with your HACCP food plan.

APPLICATIONS

- Food processing plants
- Warehouse
- Industrial Facility

ELECTRICAL INFORMATION

Model No.	LHBF-100	LHBF-150	LHBF-200	LHBF-240
Power Consumption (±5%)	100W	150W	200W	240W
Power Supply	MEANWELL			
Input Voltage	100-277/ 277-480 VAC 50 / 60 Hz			
Power Factor	0.92			
Surge Protection	4kV line-line, 6kV line-earth			
Driver Type	Constant Current (CC)			
Control	1-10V Dimmable, 12V Plug-and- Play PIR sensor			
	12V Plug-and- Play Microwave Motion Sensor			

OPTIC INFORMATION

LED Type	LED 3030			
Luminous Flux (±10%)	14000lm	21000lm	28000lm	33600lm
Efficacy(5000K Ra80)	140 LM/W			
Correlated Colour Temperature	5000K (3000K, 4000K, 6000K optional)			
Colour Rendering Index	Ra 80 (Ra 90 optional)			
Beam Angle	110°			
UGR level	<25			

DIMENSIONS AND MOUNT

Product Dimension(mm)	Φ460*177mm
Luminaire Net Weight	6.7±0.3kg
Export Carton Size(mm)	520×520×170mm
Gross Weight	7.5±0.3kg
Mounting Option	Loop Hanging
Material	Aluminium Alloy Polycarbonate Optical Lens
Finish	Powder Coating
Fixture Colour	White
EPA	NA
IK Rating	IK10
IP Rating	IP65/IP69K

LIFESPAN AND WARRANTY

Operating Temperature	-30°C to + 50°C
Life Time of LED @Ta=25°C	53000hrs-L90
	110000hrs-L80
	175000hrs-L70
Warranty	5 Years

NEW FEATURES

* Please consult us for details.	
----------------------------------	--

PHOTOMETRY

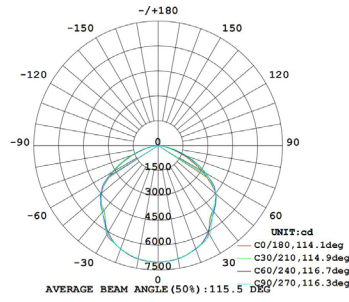

LHBF 110° PC Cover

DIMENSIONS

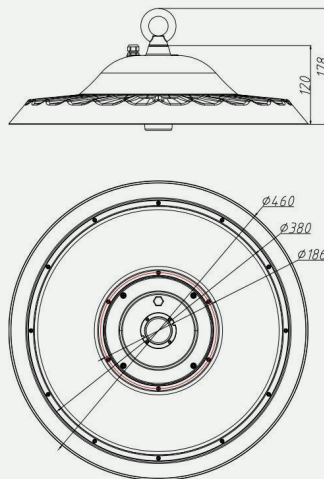

100W / 150W / 200W / 240W

MOUNTING OPTIONS



Loop Hanging

ACCESSORIES



Remote controller for motion sensor and PIR sensor

1pc for multiple luminaire.

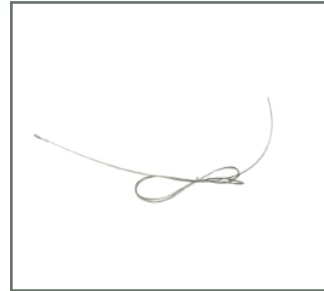

Safety rope

304 stainless steel, 0.5m long.

PRODUCT ORDERING CODES (FOOD HIGH)

SERIES	POWER	CCT (K)	OPTICS	CONTROL	EMERGENCY	MOUNT	ACCESSORY	FINISH
LHBF	100w	3	110	D (1-10V DIMMING)		L (LOOP MOUNTING)	CC (CLEAR COVER)	W (WHITE)
	150w	4		P (PIR SENSOR)			OP (OPAQUE COVER)	
	200w	6					SR (SAFETY ROPE)	
	240w						RC (REMOTE CONTROL FOR MOTION/PIR SENSOR)	

EXAMPLE ORDERING CODE For 100w, 3k, 110 degree angle, Dimming, Loop, clear cover, white

PRODUCT CODE: LHBF1003110DLCCW

PRODUCT NAME: HY-LITE